



FMC-CW-200-MAG

RIVER BEND
INDUSTRIES



Moorhead, MN 56560
218-236-1818
800-365-3070
www.riverbendind.com

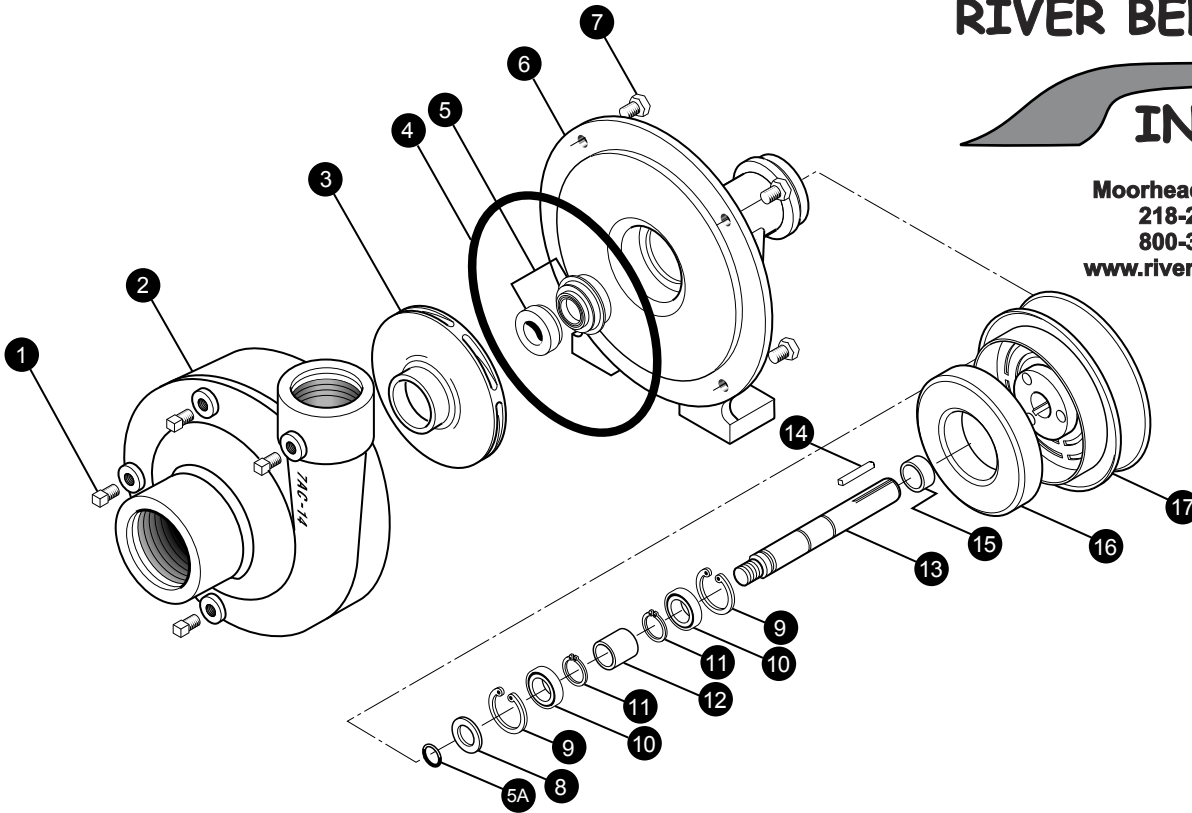

REF. #	PART #	EDP #	DESCRIPTION	REQ.
1	41110	41110	Pipe plug, 1/8" NPT	4
1	41120	41120	Pipe plug, 1/8" NPT, stainless steel (optional)	4
2	7AC-14-4	30145	Volute, 2" x 1-1/2", clockwise rotation, cast iron	1
3	BAC-26-CW-200-CI	41520	Impeller, 5-1/8" dia., right hand NF thread, cast iron	1
*4	BAC-4A	40005	"O" Ring for BAC-12 volute seal, effective Apr. '96	1
*4	BAC-4	40010	Gasket, 4 hole	1
*5	BAC-7V	40151	Seal, Viton mechanical seal (includes 40160 "O" ring)	1
5	BAC-7SC	40152	Seal, Silicon carbide mechanical seal (includes 40160 "O" Ring)(optional)	1
5A	40160	40160	"O" Ring for BAC-6 shaft	1
6	BAC-14-MAG	40285	Mounting frame, machined to accept magnetic clutch assembly	1
7	40930	40930	Cap screw, 3/8" NC x 3/4" Hex head, stainless steel (optional)	4
7	40950	40950	Cap screw, 3/8" NC x 3/4" Hex head	4
8	BAC-54	41130	Slinger	1
9	BAC-33	40810	Snap ring, internal, BAC-14 mounting frame	2
10	BAC-37	40870	Bearing, BAC-6 driven shaft	2
11	BAC-32	40790	Snap ring, external, BAC-6 driven shaft	2
12	BAC-32-S	40795	Spacer for BAC-6 shaft	1
13	BAC-6-CW	41480	Shaft, 5/8" Driven, right hand NF thread (optional)	1
13	BAC-6-CW-SS	41500	Shaft, 5/8" Driven, right hand NF thread, stainless steel	1
14	BAC-50	41080	Key, 3/16" x 3/16" x 1-1/4"	1
15	41477	41477	Spacer, clutch	1
16	41476	41476	Coil ring, 12 volt, DC activated	1
17	41479	41479	5-1/4" Pulley assembly complete with bearing and clutch driver	1
#	RK-FMC	052700	Repair kit for FMC series	-
#	41475	41475	Magnetic Clutch assembly, includes 41476, 41477, and 41479	-

* Items included in pump repair kit.