



Hannay Reels®

The reel leader.

Hannay Reels, Inc., 553 State Route 143
Westerlo, NY 12193-0159
Telephone 518-797-3791 • Toll Free 1-877-GO-REELS (467-3357)
FAX 1-800-REELING (733-5464)
INT'L FAX (518) 797-3259
Website: www.hannay.com
E-mail: reels@hannay.com

ISO 57
PARTS LIST
9000 Series
3" HOSE REELS

RIVER BEND 
INDUSTRIES

Moorhead, MN 56560
218-236-1818
800-365-3070
www.riverbendind.com

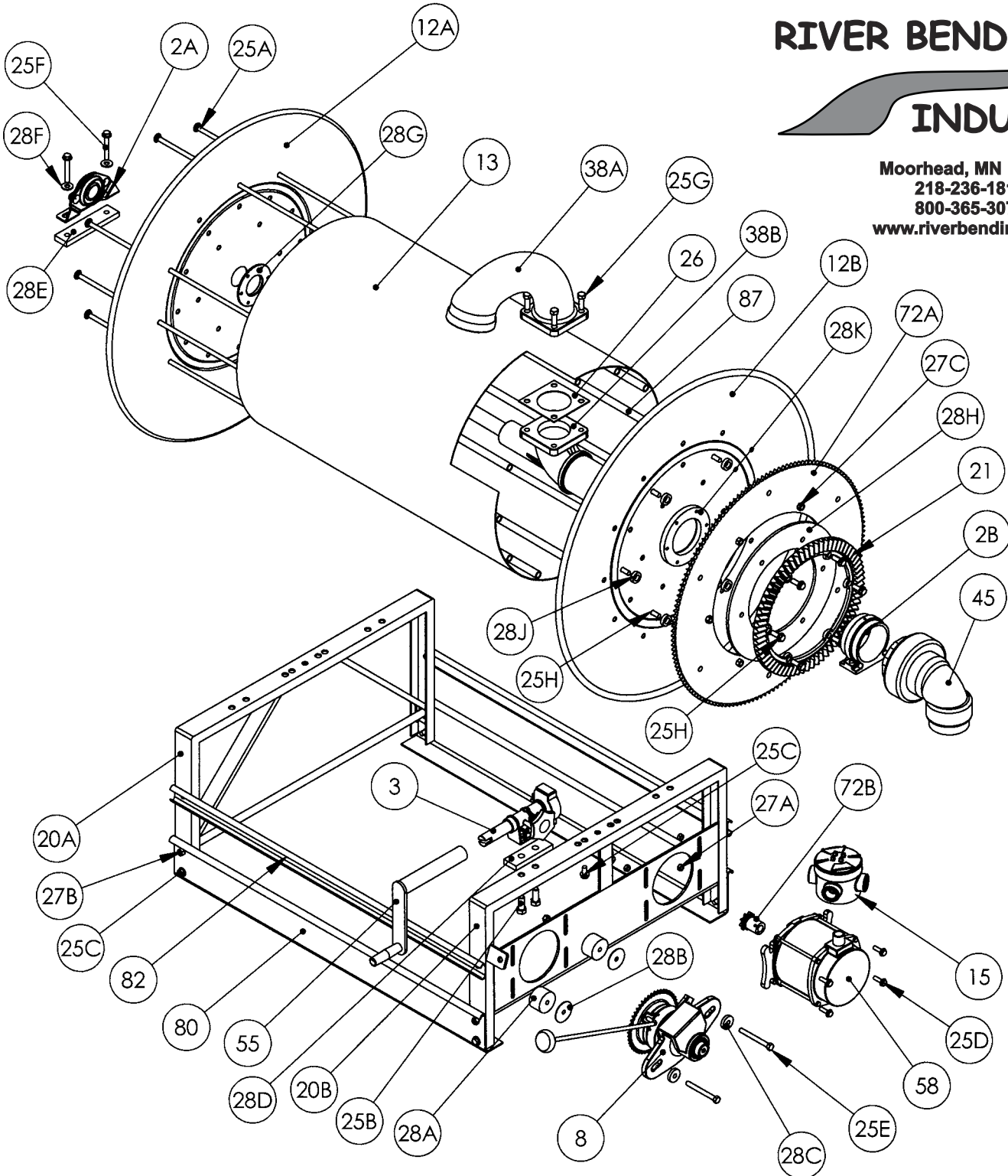

**PARTS LIST
ISO 57
3" HOSE REELS**

When ordering parts
BE SURE TO SPECIFY COMPLETE MODEL NUMBER and SERIAL NUMBER OF REEL.
USE PART NUMBER!

<u>Item No.</u>	<u>Description</u>	<u>PART NUMBER</u>	<u>Quantity</u>
2A	1" Self-Aligning Bearing Complete	9902.1400	1
2B	H-43 Front Bearing	9902.2400	1
3	Complete Manual Rewind Assy. w/H-29 Pinion Gear	9914.0210	1
3	Complete Double Bearing Rwd. Assy. (for reels "39-40" and up)	9914.0211	1
6	Chain, #35 (NOT SHOWN)	Specify Model	1
6	Chain, #40 (NOT SHOWN)	Specify Model	1
8	12/40 Clutch & Reduction Unit #35 Chain	9948.0025	1
8	12/40 Clutch & Reduction Unit #40/#35 Chain	9948.0125	1
8	Clutch & Reduction Unit (other ratios than above)	Specify Model	1
12A	Back Disc	Specify Model	1
12B	Front Disc	Specify Model	1
13	Drum, 15-1/2" Diameter	9905.3171	1
13	Drum, 20" Diameter	9905.3191	1
15	Junction Box Complete	9917.0060	1
20A	Back Frame	Specify Model	1
20B	Front Frame w/Motor Mounting Plate	Specify Model	1
21	H-28 Ring Gear	9914.0382	1
25A	3/8" Carriage Bolts (with nuts)	Specify Model	11
25B	1/2" x 1-1/4" Hex Head Bolt (for rewind assy.)	9904.1403	2
25C	3/8" x 3/4" Spinlock Bolt	9904.2201	6
25D	5/16" x 1" Spinlock Motor Mounting Bolt	9904.2102	4
25E	3/8" x 3-1/2" Hex Head Bolt (for clutch unit)	9904.1210	2
25F	3/8" x 2-1/2" Hex Head Bolt	9904.1207	2
25G	7/16" x 1-1/4" Hex Head Bolt	9904.1303	4
25H	3/8" x 1" Spinlock Bolt	9904.2202	12
26	3" Gasket, H-300G	9965.0023	1
27A	5/16" Spinlock Nut	9904.6100	4
27B	3/8" Spinlock Nut	9904.6200	Varies
27C	3/8" Jam Nut	9965.0012	6
28A	Clutch Spacer (2" OD x 1-1/4" thick)	9954.0049	2
28B	Clutch Spacer (2" OD x 1/32" thick)	9954.0048	Varies
28C	Spacer for Clutch Mtg. Bolts (1.25" OD x 13/32" ID x 1/4" thick)	9954.0047	2
28D	Aluminum Spacer Block for Aux. Crank Rewind Bearing	9954.0002	1
28E	Spacer Block for Back Bearing	9954.0001	1
28F	3/8" Flat Washer	9954.0007	2
28G	Back Washer, EH-936	9965.0015	1
28H	Ring Gear Backing Plate	9914.0582	1
28J	1" OD x 9/16" ID x 5/16" thick Sprocket Spacer	9954.0016	6
28K	H-143G Front Washer	9965.0044	1
29	Woodruff Key for Motor (not shown)	9916.0080	1
38A	3" Aluminum Riser w/3" FNPT Threads (use w/ 20" drum)	9901.7462	1
38A	3" Aluminum Riser w/2-1/2" FNPT Threads (use w/ 15.5" drum)	9901.7642	1
38B	3" Flanged Aluminum Hub Only	9901.7842	1
45	3" 90° FxF Ductile Iron Joint	9933.6500	1
45	3" 90° FxVic Aluminum Joint	9933.6302	1
55	H-18 Crank & Handle (standard 8" length)	9914.0011	1
58	12 Volt DC Exp. Proof Motor (1/2 HP, 650 RPM)	9915.0003	1
72A	Disc Sprocket, 180T35 (used on disc sizes up to 33-34)	9910.1526	1
72A	Disc Sprocket, 146T40 (used on disc sizes 35-36 and up)	9910.3128	1
72B	11T35 Motor Sprocket (lengths from 3/4" up to 1-3/4")	Specify Length	1
72B	9T40 Motor Sprocket (1-3/4" Long)	9910.0919	1
80	Frame Foot	9907.3000	2
82	Frame Brace	9907.7000	2
87	3/8" Spacer Pipe	9904.3200	11

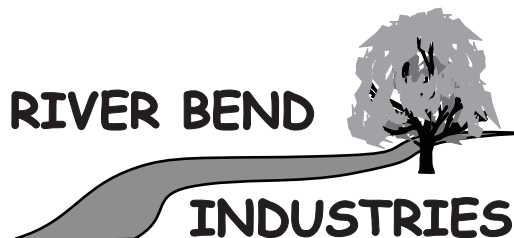

Moorhead, MN 56560
218-236-1818
800-365-3070
www.riverbendind.com