

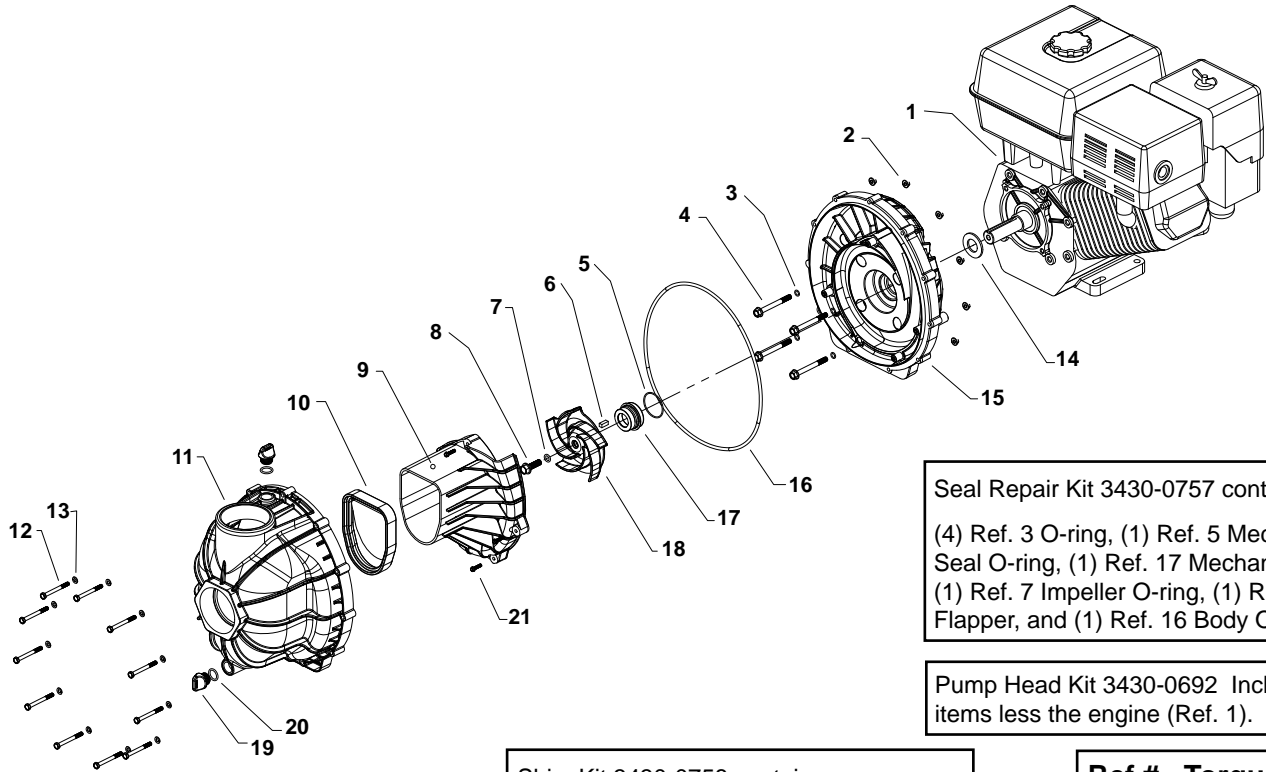

HYPRO® 1543P Series - 3" 9 HP and 13 HP Gas Engine-Driven, Self-priming, Polypropylene Transfer Pumps



Seal Repair Kit 3430-0757 contains:
 (4) Ref. 3 O-ring, (1) Ref. 5 Mechanical Seal O-ring, (1) Ref. 17 Mechanical Seal, (1) Ref. 7 Impeller O-ring, (1) Ref. 10 Flapper, and (1) Ref. 16 Body O-ring.

Pump Head Kit 3430-0692 Includes all items less the engine (Ref. 1).

Shim Kit 3430-0758 contains:
 (3) 1430-0034 Impeller Shim (not shown)
 (3) 1430-0035 Engine Shim (not shown)
 May be required on engines other than PowerPro™

Ref #	Torque Spec.
#4	10 ft.-lbs.
#8	10 ft.-lbs.
#12	45 in.-lbs.
#21	24 in.-lbs.

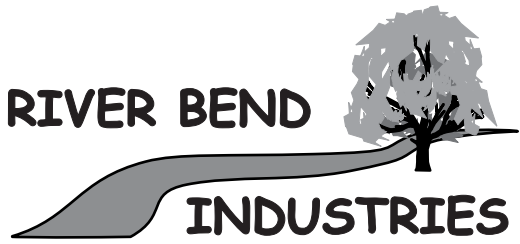

Moorhead, MN 56560
 218-236-1818
 800-365-3070
www.riverbendind.com

Ref. No.	Qty.	Part No.	Description
1	1	2543-0047	9 HP Engine, Manual Start
1	1	2543-0056	9 HP Engine, Electric Start
1A	1	2543-0048	13 HP Engine, Manual Start
1A	1	2543-0049	13 HP Engine, Electric Start
2	11	2250-0087	Hex Flange Nut
3	4	1723-0149	O-ring
4	4	2210-0182	Hex Flange Bolt
5	1	1723-0148	O-ring
6	1	1610-0069	Key (square)
7	1	1723-0142	O-ring
8	1	2210-0181	Hex Flange Bolt
9	1	0150-1543P	Pump Volute
10	1	1700-0232	Flapper Valve
11	1	0100-1543P	Pump Housing
12	11	2210-0141	Hex Head Cap Screw
13	11	2270-0115	Flat Washer
14	1	1410-0091	Slinger Ring
15	1	0750-1543P	Back Plate
16	1	1723-0146	O-ring
17	1	2120-0055	Mechanical Seal
18	1	0400-1543P	Impeller
19	2	2404-0350P	Fill/Drain Plug
20	2	1720-0230	O-ring
21	4	2210-0183	Hex Washer Head Screw