

RIVER BEND
INDUSTRIES

Moorhead, MN 56560
218-236-1818
800-365-3070
www.riverbendind.com

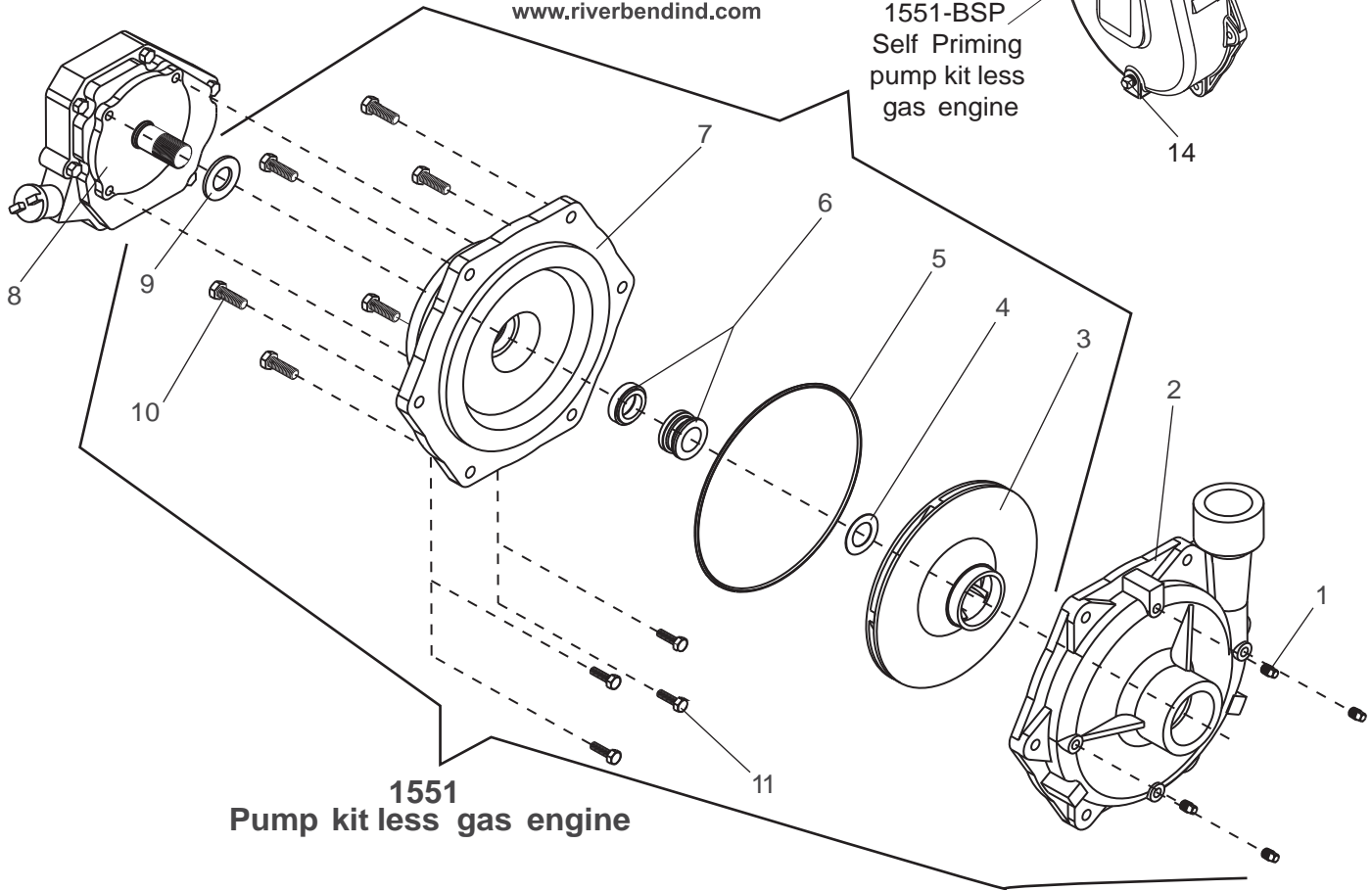

Ref. No.	Qty. Req'd.	Part No.	Description
1	4	2406-0007	Drain Plug
2	1	0153-9200C	Pump Casing (Includes SS wear ring)
3	1	0404-9200P	Impeller (Nylon)
4	1	1700-0121	Gasket
5	1	1720-0180	O-Ring
6	1	2120-0034	Mechanical Seal - Viton
7	1	0707-9200C	Flange
8	1	2541-0037	Honda Eng. (Model 1550) (GX-270PA)*
9	1	1410-0091	Slinger Ring
10	6	2210-0086	Bolt
11	4	2210-0098	Bolt
12	1	2406-0034	Priming port plug (Standard)
12	1	2406-0036	Priming port plug (BSP)
13	1	0152-9075C	Pump Casing (Standard NPT)
13	1	0152-9075C1	Pump Casing (BSP)
14	1	2406-0002	Drain plug

Note: When ordering parts, give quantity, part number, description and complete model number. Reference numbers are used ONLY to identify parts in the drawing and NOT to be used as order numbers.

Seal Kit for 1550 and 1551
No. 3430-0464 consists of:
(1) Ref . 4 Gasket
(1) Ref . 5 O-ring
(1) Ref . 6 Mechanical Seal