

Models 9910-D50, D50AP-A, & D50-B

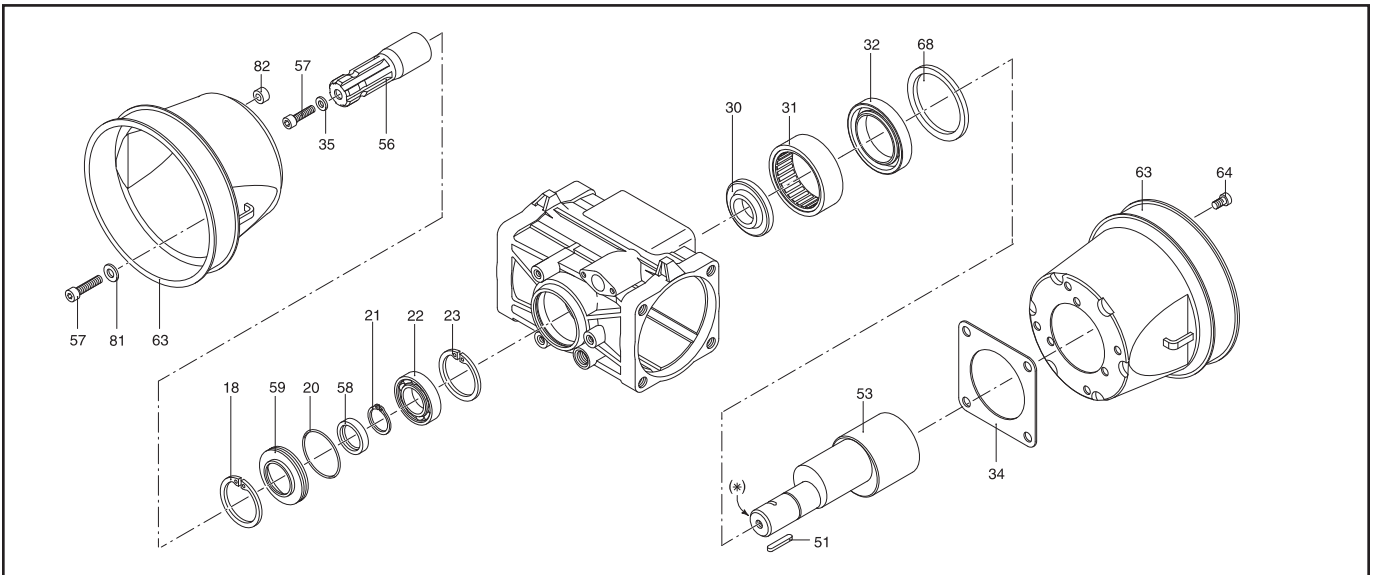
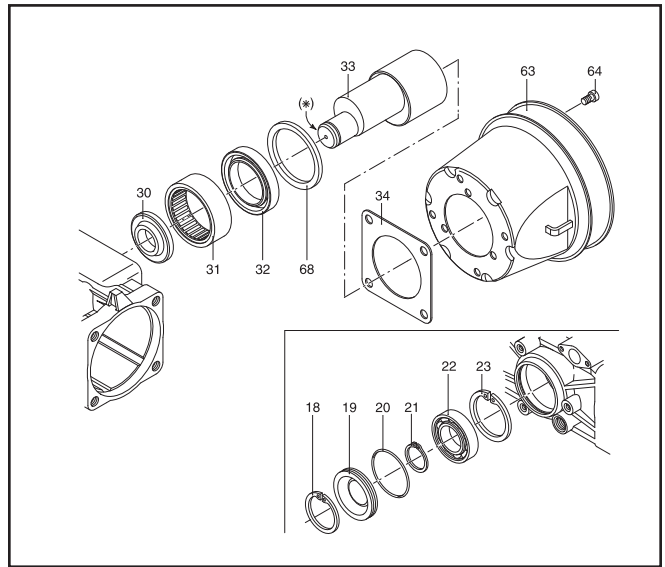
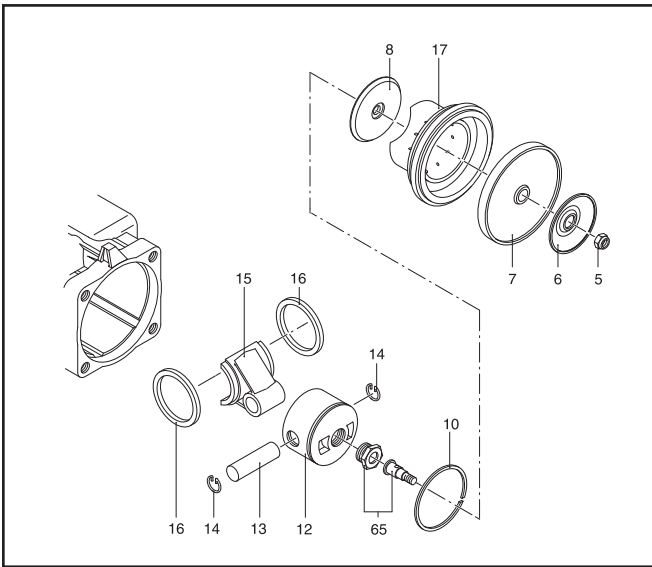
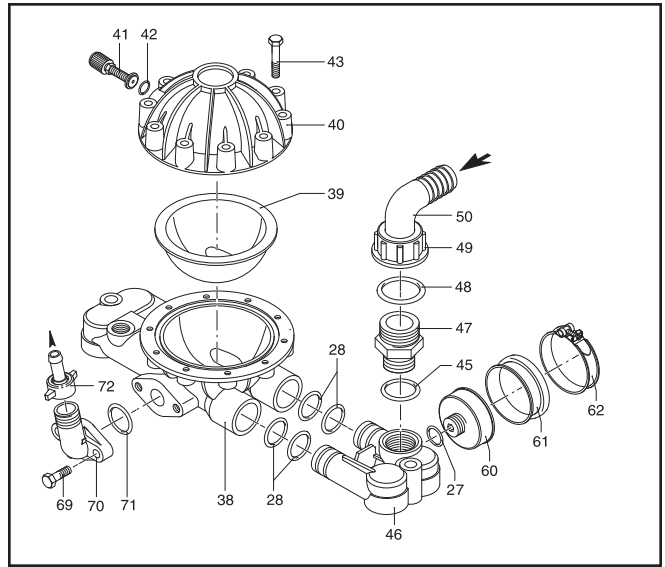
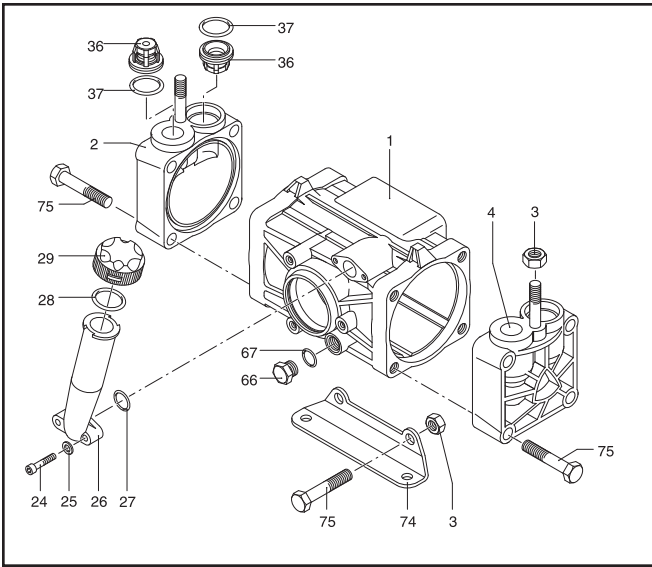

Hypro Models 9910-D50, D50AP-A, & D50-B

Ref. No.	Part Number	Description	Qty.
1	9910-650011	Pump body	1
2	9910-650102	Left head SX	1
3	9910-320130	Nut	4
4	9910-650101	Right head DX	1
5	9910-160311	M 8 H 10 Nut	2
6	9910-650390	Retaining washer	2
7 ²	9910-650085	Diaphragm Desmopan (Std.)	2
7	9910-650082	Diaphragm Buna-N (Opt.)	2
7	9910-65008T	Diaphragm Buna-N with Teflon Coating (Opt.)	2
8	9910-650090	Diaphragm support washer	2
10	9910-650190	Piston ring	2
12	9910-650121	Piston	2
13	9910-650071	Piston pin	2
14	9910-160691	Retainer ring	4
15	9910-650142	Connecting rod	2
16	9910-650130	Con rod rings	2
17	9910-650111	Sleeve	2
18	9910-200390	Retainer ring	1
19	9910-650040	Pump body cover	1
20 ¹	9910-650920	O-Ring	1
21	9910-650480	Retainer ring	1
22	9910-230330	Bearing	1
23	9910-161050	Retainer ring	1
24	9910-850850	Bolt	2
25	9910-550331	Washer	2
26	9910-650030	Oil Sight Glass	1
27 ¹	9910-180101	O-Ring	2
28 ¹	9910-550040	O-Ring	5
29	9910-550056	Sight Glass cap	1
30	9910-650160	Bearing spacer	1
31	9910-650200	Roller bearing	1
32	9910-1400150	Shaft seal	1
33	9910-650170	Shaft	1
34	9910-1400140	Flange	1
35	9910-961340	Washer	1
36 ³	9910-659050	Complete valve	4
37 ^{2,3,1}	9910-320030	O-Ring	4
38	9910-659204	Complete lower air chamber	1

Ref. No.	Part Number	Description	Qty.
39 ²	9910-650520	Air chamber diaphragm	1
39	9910-65052T	Air chamber diaphragm-Teflon(Opt.)	1
40	9910-659206	Upper air chamber	1
41	9910-180020	Air valve (includes #42)	1
42 ¹	9910-650542	Gasket	1
43	9910-621780	Bolt	10
45 ¹	9910-390290	O-Ring	1
46	9910-650150	Suction manifold	1
47	9910-450120	Threaded adapter	1
48	9910-390290	O-Ring	1
49	9910-580060	Ring nut	1
50	9910-580040	Hose barb 1-1/4"	1
51	9910-650250	Key	1
53	9910-650171	Through-shaft (AP-A)	1
56	9910-650300	PTO shaft adapter	1
57	9910-680350	Bolt	4
58	9910-650490	Seal (AP-A model)	1
59	9910-650041	Spacer (AP-A model)	1
60	9910-650660	Diaphragm holder	1
61	9910-650670	Dampener diaphragm	1
62	9910-650690	Clamp	1
63	9910-1500350	Plastic shield	2
64	9910-820670	Bolt	4
65	9910-659080	Complete bushing	2
66	2406-0023	Drain plug, oil	1
67 ¹	9910-740290	O-Ring	1
68	9910-1400110	Flange	1
69	9910-540290	Bolt	2
70	9910-450145	Discharge flange housing	1
71 ¹	9910-550350	O-Ring	1
72	9910-110130	Hose barb and Nut 1/2"	1
74	9910-320392	Base	2
75	9910-750060	Bolt	10
81	9910-380241	Washer	3
82	9910-1200521	Spacer	3

¹ Denotes O-Ring Kit 9910-KIT1919

² Denotes Diaphragm Kit (Desmopan) 9910-KIT1725

³ Denotes Valve Kit 9910-KIT1920



9910-KIT1725 Diaphragm Kit Desmopan	
Ref. No.	Qty.
72	2
37	4
39 ²	1



9910-KIT1920 Valve Kit	
Ref. No.	Qty.
36	4
37	4

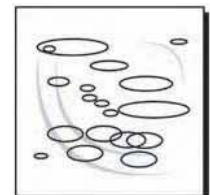

9910-KIT1919 O-Ring Kit	
Ref. No.	Qty.
20	1
27	2
28	5
37	4
42	1
45	1
67	1
71	1

Ref. No.	Description	Tightening Torque	
		In. Lbs.	Nm
3	Nut	271.0	29.4
5	Nut	171.4	19.6
43	Bolt	171.4	19.6
57	Bolt	171.4	19.6
64	Bolt	87.5	9.8
66	Plug	171.4	19.6
69	Plug	171.4	19.6
75	Bolt	435.0	49.0

RIVER BEND

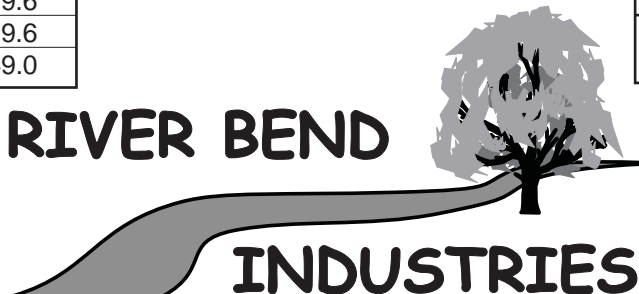

INDUSTRIES

Moorhead, MN 56560

218-236-1818

800-365-3070

www.riverbendind.com