

MP PUMPS SERVICE PARTS LIST

Double Seal Pumpak for Engine or Pedestal Drive

FM8 2" x 2"

MP PUMPS, INC.
34800 BENNETT • FRASER, MI 48026-1686

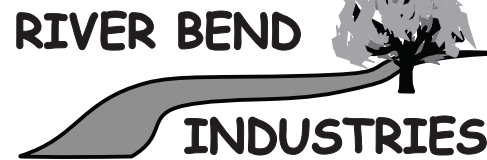
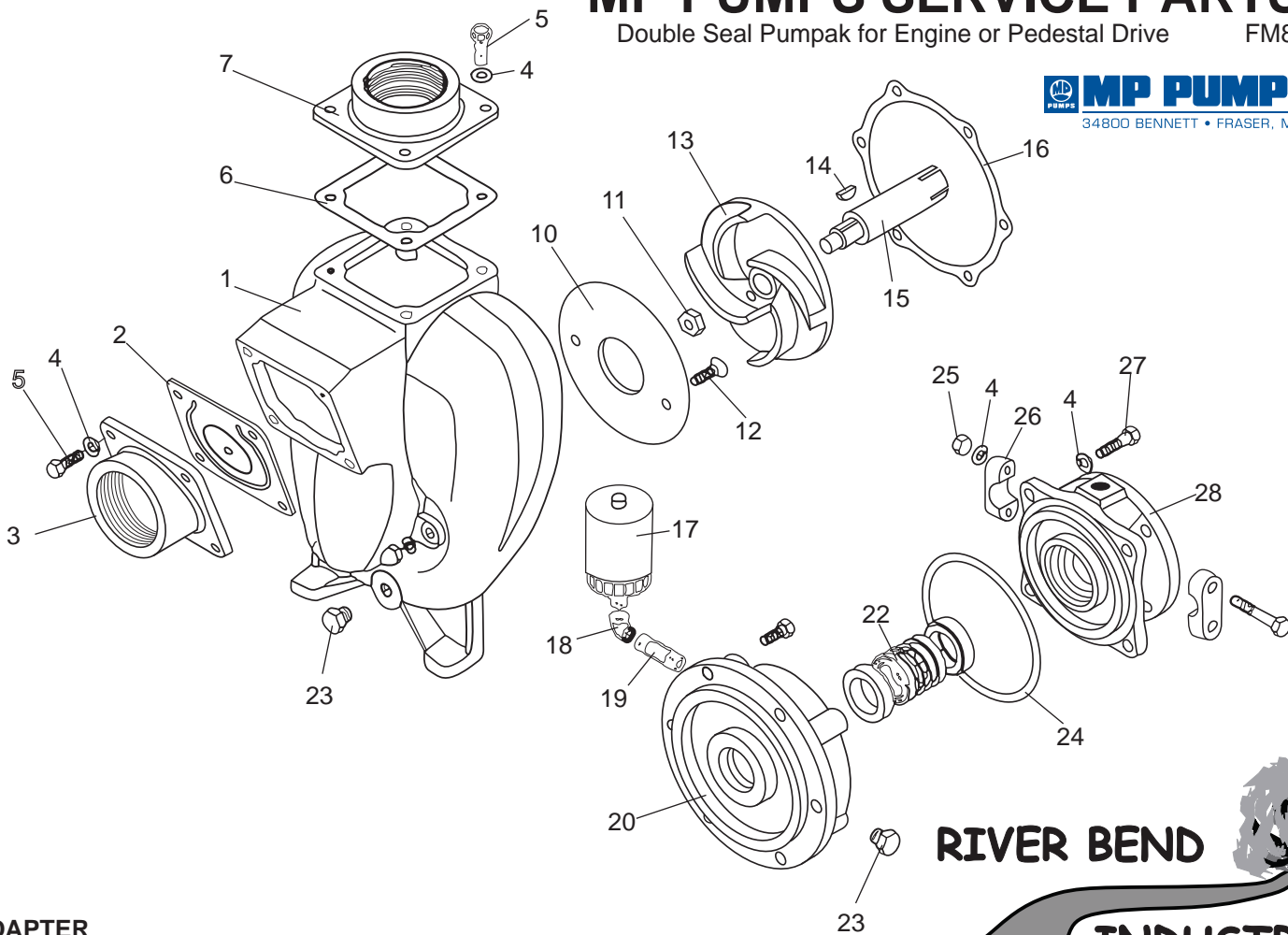

Moorhead, MN 56560
218-236-1818
800-365-3070
www.riverbendind.com

ADAPTER

20	28508	ADAPTER - CAST IRON	1
28	28506	ADAPTER - CAST IRON	1
23	21267	PIPE PLUG - S.S. - 1/4" NPT	1
27	21250	CAPSCREW - S.S. - 5/16"-18 X 1-1/8"	4
4	21238	LOCKWASHER - S.S. - 5/16"	4
17	28575	OIL RESERVOIR -1/4" NPT	1
18	41672	ELBOW - STL - 1/4" NPT X 900	1
19	28635	PIPE NIPPLE - STL -1/4" NPT X 1-1/2"	1
24	28509	GASKET - ADAPTER to ADAPTER	1

HOUSING

	23021	HOUSING ASSY - CAST IRON -INC.	
1	22251	HOUSING - CAST IRON	1
5	21242	CAPSCREW - S.S. - 5/16"-18 X 7/8"	8
4	21238	LOCKWASHER - S.S. - 5/16"	8
21	24965	CAPSCREW - S.S. - 5/16"-18 X 3/4"	6
23	21267	PIPE PLUG - S.S. -1/4" NPT	1
6	22256	GASKET - OUTLET to ADAPTER	1
16	22255	GASKET - HOUSING to ADAPTER	1

CLAMP

	23002	CLAMP ASSY - 3/4" DIA. SHAFT -INC.	1
26	21946	CLAMP	2
29	21264	CAPSCREW - S.S. - 5/16"-18 X 1-3/4"	2
4	21238	LOCKWASHER - S.S. - 5/16"	2
25	21284	HEXNUT - S.S. - 5/16"-18	2

	23003	CLAMP ASSY - 7/8" DIA. SHAFT - INC.	1
26	21954	CLAMP	2
29	21264	CAPSCREW - S.S. - 5/16"-18 X 1-3/4"	2
4	21238	LOCKWASHER - S.S. - 5/16"	2
25	21284	HEXNUT - S.S. - 5/16"-18	2

IMPELLER

13	28512	IMPELLER - CAST IRON - 4.84 DIA.	1
13	28667	IMPELLER - CAST IRON - 4.47 DIA.	1
13	28668	IMPELLER - CAST IRON - 4.66 DIA.	1
13	28669	IMPELLER - CAST IRON - 3.88 DIA.	1
14	21163	WOODRUFF KEY - S.S. - 5/8" X 5/32"	1
15	28531	DRIVE SLEEVE - S.S. - 3/4" DIA; BORE	1
15	28532	DRIVE SLEEVE - S.S. - 7/8" DIA. BORE	1
11	22621	JAM NUT - S.S. -1/2"-20	1

FLANGE

3	22263	INLET FLANGE - CAST IRON - 1-1/2"	1
3	22387	INLET FLANGE - CAST IRON - 2"	1
7	22266	OUTLET FLANGE - CAST IRON -1-1/2"	1
7	22311	OUTLET FLANGE - CAST IRON - 2"	1

SEAL

22	28574	DOUBLE SEAL ASSY 1.00" DIA. SHAFT	1
----	-------	-----------------------------------	---

FLAPPER - SUCTION CHECK VALVE

2	23022	FLAPPER ASSY	1
2	26097	FLAPPER ASSY - EPDM - OPTIONAL	1

WEAR PLATE

	23024	WEAR PLATE ASSY - INC.	
10	22260	WEAR PLATE - STL	1
12	21249	SCREW- 8.S. -5/16"-18 X 1"	2
8	21237	ACORN NUT - S.S. - 5/16"-18	2
9	21248	ANNULAR GASKET - 5/16"	2