

SELF-PRIMING CENTRIFUGAL PUMP SERIES "G"

EXPLODED VIEW PARTS DIAGRAM

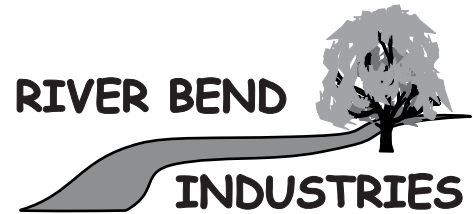

Moorhead, MN 56560
218-236-1818
800-365-3070
www.riverbendind.com

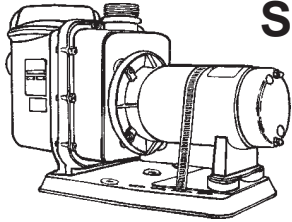
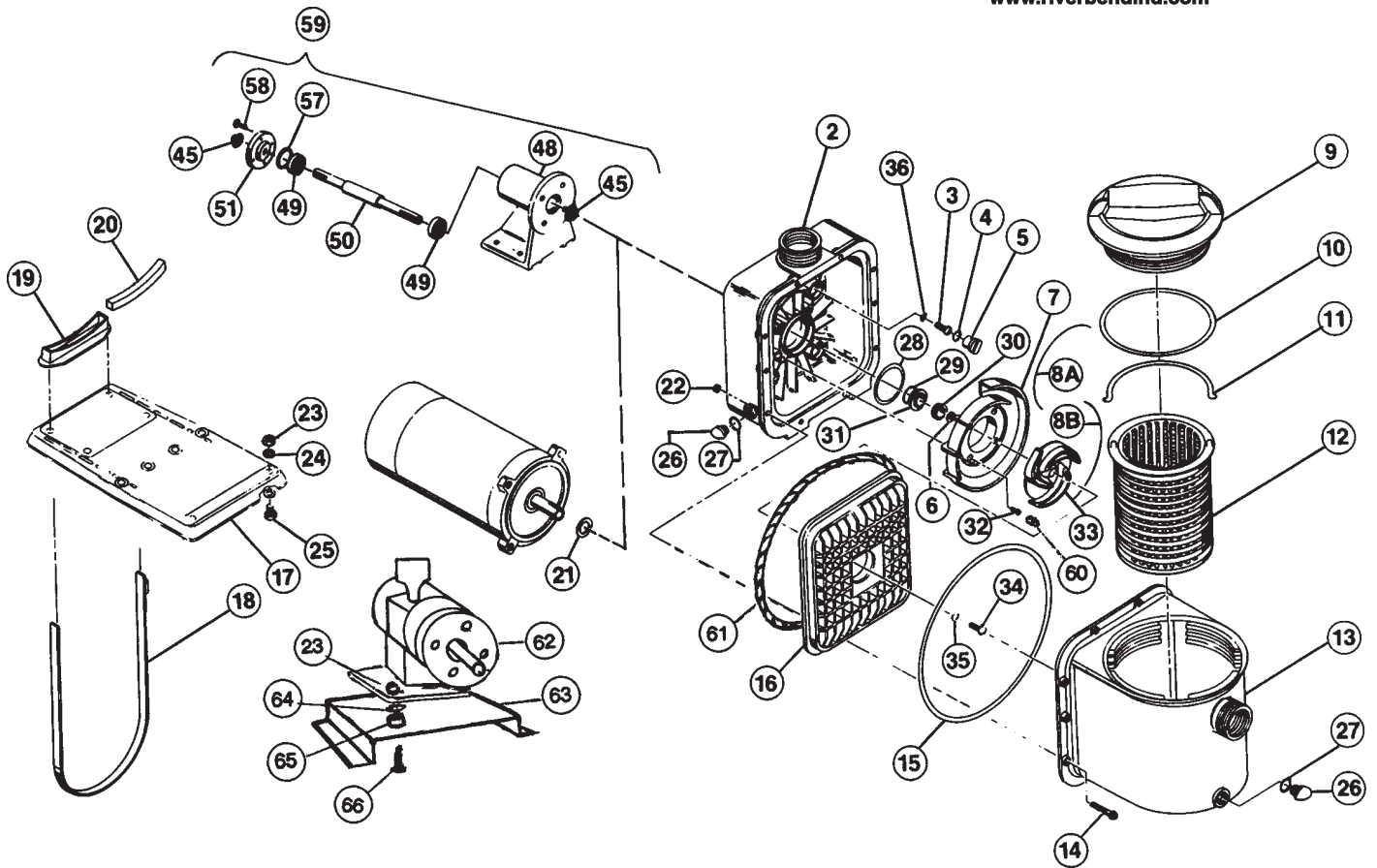

The chemical process industry (CPI) type seal has VITON elastomers and a special high grade carbon face for better service in chemical applications.

NOTE: All specifications, as shown, are subject of change without previous notice

*servicing
industry
world-
wide*

PACER® PUMPS
Div. of ASM Industries, Inc.

DISTRIBUTED BY:

(Printed in U.S.A.)

"G" PUMP PARTS LIST

ITEM#	PART #	GROUP	DESCRIPTION	QTY./PUMP	ITEM#	PART #	GROUP	DESCRIPTION	QTY./PUMP
2	58-180120		BODY, pump, NORYL, NPT	1	28	58-182271		O-RING, volute, BUNA-N	1
	58-182120		BODY, pump, NORYL, BSP	1		58-182272		O-RING, volute, EPDM	1
	58-180160		BODY, pump, RYTON, NPT	1		58-182273		O-RING, volute, VITON	1
3	58-183810		SCREW, body to motor, or pedestal	1	29	58-097671		O-RING, seal, BUNA-N	1
			3/8-16 x 7/8", stainless steel	4		58-097672		O-RING, seal, EPDM	1
	58-183891		SCREW, body to motor, or pedestal	1		58-097673		O-RING, seal, VITON	1
			3/8-16 x 7/8", Hastelloy C	4	29, 30	58-071411	**	SEAL, shaft, BUNA-N, 316 stainless steel, carbon ceramic	1
	58-183893		SCREW, body to motor, or pedestal	1	& 31	58-071412	**	SEAL, shaft, EPDM, 316 stainless steel, carbon ceramic	1
			3/8-16 x 7/8", Titanium	4		58-071414	**	SEAL, shaft, VITON, 316 stainless steel, carbon ceramic	1
4	58-124571		O-RING, screw plug, BUNA-N	4		58-071415	**	SEAL, shaft, Hast C/teflon/silicon carbide	1
	58-124572		O-RING, screw plug, EPDM	4		58-071492 SG		SEAL, shaft, Non-metallic, ECTFE, EPDM, siliconized graphite	1
	58-124573		O-RING, screw plug, VITON	4		58-071494 SG		SEAL, shaft, Non-metallic, ECTFE, VITON, siliconized graphite	1
5	58-183320		PLUG, screw protector, gray NORYL, NORYL pumps only	4		58-4625011	**	SEAL, shaft, 316 stainless steel/BUNA-N/siliconized graphite	1
	58-183390		PLUG, screw protector, white, ECTFE, RYTON pumps only	4		58-4625012	**	SEAL, shaft, 316 stainless steel/EPDM/siliconized graphite	1
6	58-184111		SHIM, impeller, .006"	as required		58-4625013	**	SEAL, shaft, 316 stainless steel/VITON/siliconized graphite	1
	58-184112		SHIM, impeller, .015"	as required	32	58-183510		SCREW, volute, #10-16 x 3/4" stainless steel	4
	58-184113		SHIM, impeller, .030"	as required		58-134891		SCREW, volute, #10-16 x 3/4" Hastelloy C	4
7	58-180420	C	VOLUTE, NORYL, for 619 impeller	1		58-134893		SCREW, volute, #10-16 x 3/4" Titanium	4
	58-210420	A	VOLUTE, NORYL, for 617 impeller	1	33	58-061720	A	IMPELLER, NORYL, (# on part), keyed shaft 1	1
	58-210920	B	VOLUTE, NORYL, for 618 impeller	1		58-061820	B	IMPELLER, NORYL, (# on part), keyed shaft 1	1
	58-180220	D	VOLUTE, NORYL, for 620 impeller	1		58-061920	C	IMPELLER, NORYL, (# on part), keyed shaft 1	1
	58-211020	E	VOLUTE, NORYL, for 621 impeller	1		58-062020	D	IMPELLER, NORYL, (# on part), keyed shaft 1	1
	58-180460	C	VOLUTE, RYTON, for 619 impeller	1		58-062120	E	IMPELLER, NORYL, (# on part), keyed shaft 1	1
	58-210460	A	VOLUTE, RYTON, for 617 impeller	1		58-061760	A	IMPELLER, RYTON, (# on part), keyed shaft 1	1
	58-210960	B	VOLUTE, RYTON, for 618 impeller	1		58-061860	B	IMPELLER, RYTON, (# on part), keyed shaft 1	1
	58-180260	D	VOLUTE, RYTON, for 620 impeller	1		58-061960	C	IMPELLER, RYTON, (# on part), keyed shaft 1	1
	58-211060	E	VOLUTE, RYTON, for 621 impeller	1		58-062060	D	IMPELLER, RYTON, (# on part), keyed shaft 1	1
8A	58-181271	A,B,C,D,E	O-RING, segment, BUNA-N, left	1		58-062160	E	IMPELLER, RYTON, (# on part), keyed shaft 1	1
	58-181272	A,B,C,D,E	O-RING, segment, EPDM, left	1	34	58-188810		SCREW, impeller, stainless steel, 1/4-28 x 5/8"	1
	58-181273	A,B,C,D,E	O-RING, segment, VITON, left	1		58-188861		SCREW, impeller, RYTON encapsulated, 1/4-28 x 7/16"	1
8B	58-181371	A,B,C	O-RING, segment, BUNA-N, right	1		58-188891		SCREW, impeller, Hastelloy C, 1/4-28 x 5/8"	1
	58-181372	A,B,C	O-RING, segment, EPDM, right	1		58-188893		SCREW, impeller, Titanium, 1/4-28 x 5/8"	1
	58-181373	A,B,C	O-RING, segment, VITON, right	1	35	58-184571		O-RING, impeller screw, BUNA-N	1
	58-181471	D,E	O-RING, segment, BUNA-N, right	1		58-184572		O-RING, impeller screw, EPDM	1
	58-181472	D,E	O-RING, segment, EPDM, right	1		58-184573		O-RING, impeller screw, VITON	1
	58-181473	D,E	O-RING, segment, VITON, right	1	36	58-182471		O-RING, body to motor or pedestal, BUNA-N	4
9	58-181820		COVER, strainer, NORYL	1		58-182472		O-RING, body to motor or pedestal, EPDM	4
	58-181860		COVER, strainer, RYTON	1	45	58-195571		O-RING, body to motor or pedestal, VITON	4
	58-181890		COVER, strainer, clear POLYCARB	1		58-195573		SEAL, LIP, BUNA-N, .710" ID	2
10	58-182071		O-RING, strainer cover, BUNA-N	1		58-195573		SEAL, LIP, VITON, .710" ID	2
	58-182072		O-RING, strainer cover, EPDM	1	48	58-195190		PEDESTAL, bearing, cast iron	1
	58-182073		O-RING, strainer cover, VITON	1	49	58-195490		BEARING, ball, .787" ID	2
11	58-181910		HANDLE, basket strainer, S.S.	1	50	58-195710		SHAFT, 5/8" x 3/4", keyed stainless steel	1
	58-181990		HANDLE, basket strainer, Teflon coated stainless steel	1		58-195791		SHAFT, 5/8" x 3/4", keyed Hastelloy C	1
12	58-180940		BASKET STRAINER, Polypropylene, NORYL pumps only	1		58-195793		SHAFT, 5/8" x 3/4", keyed Titanium	1
	58-180990		BASKET STRAINER, ECTFE, RYTON pumps only	1	51	58-195310		PLATE, end, stainless steel	1
13	58-181620		HOUSING, basket strainer, NORYL, NPT	1	57	58-195610		SHIM, stainless steel	as required
	58-181720		HOUSING, basket strainer, NORYL, BSP	1	58	58-252510		SCREW, hex, 1/4"-20 x 3/4" stainless steel	4
	58-181660		HOUSING, basket strainer, RYTON, NPT	1	59	58-195002		PEDESTAL, assembly includes items 45, 48, 49, 50, 51, 57 & 58	1
14	58-103910		SCREW, strainer housing, 1/4"-20 x 1-5/8" stainless steel	10		58-195002H		PEDESTAL, assembly with Hastelloy shaft, includes items 45, 58, 49, 50, 51, 57 & 58	1
15	58-185871		O-RING, volute plate, BUNA-N	1		58-195002T		PEDESTAL, assembly with Titanium shaft, includes items 45, 58, 49, 50, 51, 57 & 58	1
	58-185872		O-RING, volute plate, EPDM	1	60	58-210890B		VOLUTE SCREW PLUG, Teflon w/BUNA-N o-ring, for pumps with non-metallic solution contact only	4
	58-185873		O-RING, volute plate, VITON	1		58-210890L		VOLUTE SCREW PLUG, Teflon w/EPDM o-ring, for pumps with non-metallic solution contact only	4
16	58-183120		VOLUTE PLATE, NORYL, flat	1		58-210890V		VOLUTE SCREW PLUG, Teflon w/VITON o-ring, for pumps with non-metallic solution contact only	4
	58-183121		VOLUTE PLATE, Noryl rubber lined BUNA-N	1	61	58-128390		GASKET, Teflon Gor-Tex, RYTON pumps only	1
	58-180322		VOLUTE PLATE, Noryl rubber lined EPDM	1	62	58-092601		MOTOR, pneumatic	1
	58-183190		VOLUTE PLATE, White, ECTFE, flat, RYTON pumps only	1	63	58-0929		BASEPLATE, pneumatic motor, painted steel	1
17	58-184640		BASEPLATE, Polypropylene	1	64	58-0794		SHIM, .062", plated steel	8
18	58-093410		STRAP, stainless steel, motor, retaining	1	65	58-077990		SPACER, 5/8", nylon	4
19	58-182590		SADDLE, for 5-1/2" diameter electric motor	1	66	58-2167		SCREW, 5/16-18 x 1-1/2", plated steel	4
	58-182890		SADDLE, for 6-5/8" diameter electric motor	1					
20	58-184771		PAD, saddle, rubber	1					
21	58-183471		SLINGER, BUNA-N	1					
22	58-072110		NUT, hex, body, stainless steel 1/4"-20	1					
23	58-0745		KEPNUT, 5/16"-18, plated steel	as required					
24	58-0730		WASHER, flat 5/16", plated steel	2					
25	58-0729		SCREW, 5/16"-18 x 1", plated steel	2					
26	58-072320		PLUG, drain, gray NORYL	2					
	58-072360		PLUG, drain, brown RYTON	2					
27	58-100971		O-RING, drain plug, BUNA-N	2					
	58-100972		O-RING, drain plug, EPDM	2					
	58-100973		O-RING, drain plug, VITON	2					

*GROUP Three item numbers are listed with a letter in the "GROUP" column. The parts listed under each item number are very similar but differ in detail. Only certain combinations of these parts are suitable for proper operation of the pump. Do not mix GROUPS. A simplified chart follows. START WITH THE IMPELLER AND THEN MATCH THE OTHER PARTS TO IT.

**** Standard seals listed here. Consult factory for latest developments in shaft seal technology.**

GROUP	IMPELLER	VOLUTE	O-RING SEGMENTS (2 per pump)
A	58-0617	58-2104	58-1812 and 58-1813
B	58-0618	58-2109	58-1812 and 58-1813
C	58-0619	58-1804	58-1812 and 58-1813
D	58-0620	58-1802	58-1812 and 58-1814
E	58-0621	58-2110	58-1812 and 58-1814